

(12) INTERNATIONAL APPLICATION PUBLISHED UNDER THE PATENT COOPERATION TREATY (PCT)

(19) World Intellectual Property Organization  
International Bureau



(43) International Publication Date  
6 May 2004 (06.05.2004)

PCT

(10) International Publication Number  
WO 2004/038838 A2

(51) International Patent Classification<sup>7</sup>: H01M 8/00

[JP/JP]; 92-118, Urago-cho 2-chome, Yokosuka-shi, Kanagawa 237-0062 (JP).

(21) International Application Number:  
PCT/JP2003/012973

(74) Agents: MIYOSHI, Hidekazu et al.; 9th Floor, Toranomon Daiichi Building, 2-3, Toranomon 1-chome, Minato-ku, Tokyo 105-0001 (JP).

(22) International Filing Date: 9 October 2003 (09.10.2003)

(25) Filing Language: English

(81) Designated States (national): CN, KR, US.

(26) Publication Language: English

(84) Designated States (regional): European patent (DE, FR, GB).

(30) Priority Data:  
2002-306852 22 October 2002 (22.10.2002) JP

Published:  
— without international search report and to be republished upon receipt of that report

(71) Applicant (for all designated States except US): NISSAN MOTOR CO., LTD. [JP/JP]; 2, Takara-cho, Kanagawa-ku, Yokohama-shi, Kanagawa 221-0023 (JP).

For two-letter codes and other abbreviations, refer to the "Guidance Notes on Codes and Abbreviations" appearing at the beginning of each regular issue of the PCT Gazette.

(72) Inventor; and  
(75) Inventor/Applicant (for US only): UOZUMI, Tetsuo

(54) Title: FUEL CELL SYSTEM

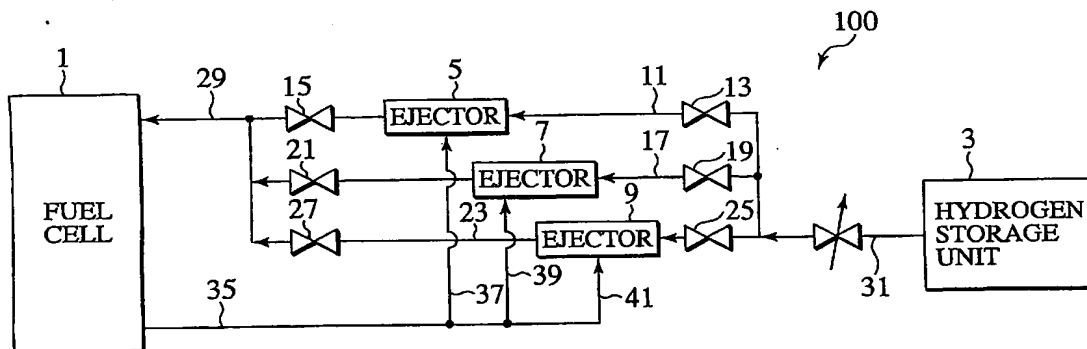

(57) Abstract: Three ejectors 5, 7, 9 with differences in specification are connected in parallel between a hydrogen storage unit 3 and a fuel cell 1. Respective ejectors 5, 7, 9 allow excess hydrogen, discharged from the fuel cell 1, to pass through a hydrogen recirculating common flow passage 35 and to be recirculated through three recirculation branch flow passages 37, 39, 41. Shut-off mechanisms 13, 15, 19, 21, 25, 27 are disposed at both upstream and downstream sides of the respective ejectors 5, 7, 9, with closing and opening of the shut-off mechanisms located at both the upstream and downstream sides of the respective ejectors 5, 7, 9 permitting the three ejectors 5, 7, 9 to be properly used.

WO 2004/038838 A2